

# T6.300

## Specifications

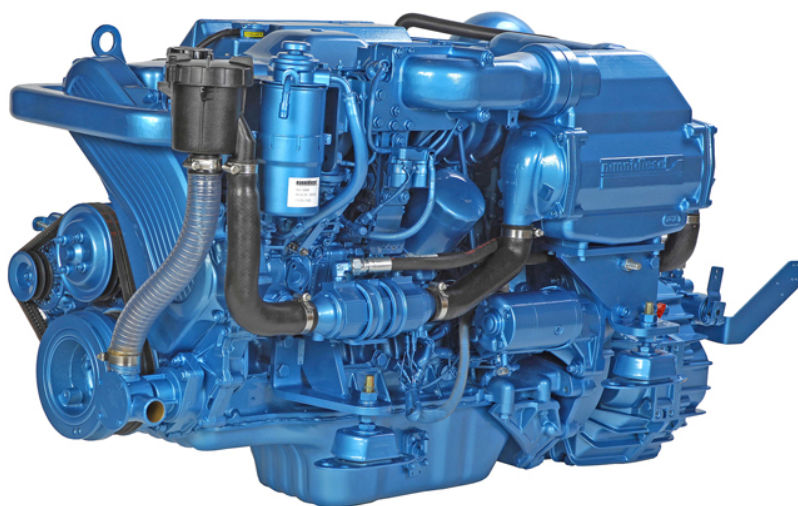

<b>Power at crankshaft</b>	224.4 kW [305 hp]	<b>Engine base</b>	Toyota
<b>Displacement</b>	4.2 l [254 in <sup>3</sup> ]	<b>Fuel system</b>	Direct injection Mechanical governor
<b>Configuration</b>	6 cylinders in line 4 valves per cylinder	<b>Air intake</b>	Turbocharged with intercooler
<b>Operation type</b>	4 stroke Diesel	<b>Cooling</b>	Closed cooling with heat exchanger
<b>Bore &amp; Stroke</b>	94 x 100 mm [3.7 x 3.94 in]	<b>Mounting angle</b>	7° Front up 0° Front down
<b>Compression ratio</b>	15.7:1	<b>Alternator</b>	12 Volt 80 Amp
<b>Rated speed</b>	3600 rpm	<b>Rating</b>	M6
<b>Idle speed</b>	700 rpm	<b>Emission compliance</b>	RCD 94/25/EC BSO 2
<b>Peak torque</b>	760 Nm		
<b>Peak torque speed</b>	2400 rpm		
<b>Dry weight</b> with TTM50A	469 kg [1033 lb]		

# T6.300

224.4 kW [305 hp] @ 3600 rpm

## TECHNICAL DESCRIPTION

### Engine block

- 6 cylinders in line
- 4 valves per cylinder
- Watercooled exhaust manifold
- Internal balancers

### Fuel system

- Direct injection, mechanical governor
- Fuel filter with hand primer

### Lubrication system

- Replaceable full-flow oil filter
- Oil dipstick
- Transmission oil cooler

### Cooling system

- Closed cooling with heat exchanger
- Gear driven self-priming raw water pump
- Coolant circulating pump
- Water cooled exhaust elbow

### Electrical system & Instrumentation

- 12V 80A alternator
- 12V Electrical system
- Complete instrumentation including key switch and alarms

### Air intake

- Dry turbocharger
- Intercooler

### Other features

- Flexible engine mounting

### Optional equipment & accessories

- Complete marine propulsion systems
- Marine transmission adaptation kits
- Throttle and shift controls
- Additional instrumentation, Flying bridge extension harness
- Water boiler systems
- Stuffing box connections
- Complete fuel systems
- Complete exhaust systems
- Trolling valve
- 12V 120A alternator
- Two pole electrical system

## RATING

- Up to 500 annual operating hours
- Load factor up to 35%
- Full power for no more than 30 minutes out of each 8 hours of operation. The remaining operation time must be at or below cruising speed

## TRANSMISSIONS

### Shaft line

- TTM50A
- ZF220PL
- ZF63
- ZF63A
- ZF63IV
- ZF80A

Contact your local dealer for more details and availability for transmission model and type.

## PERFORMANCE CURVES

### Power at crankshaft

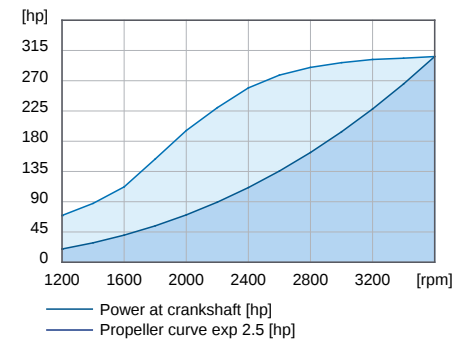

### Torque at crankshaft

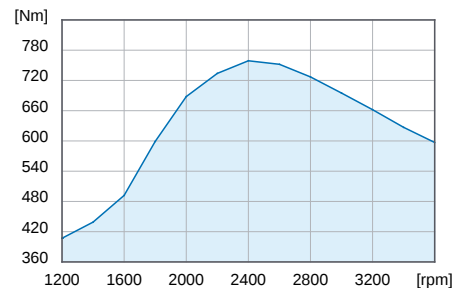

### Fuel consumption

At calculated propeller load exp 2.5

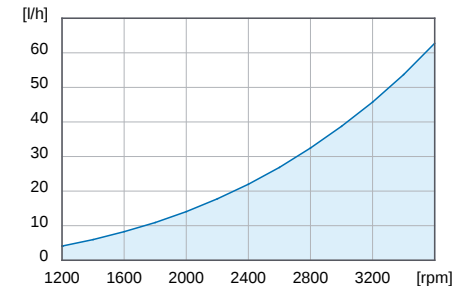

## DIMENSIONS WITH ZF63

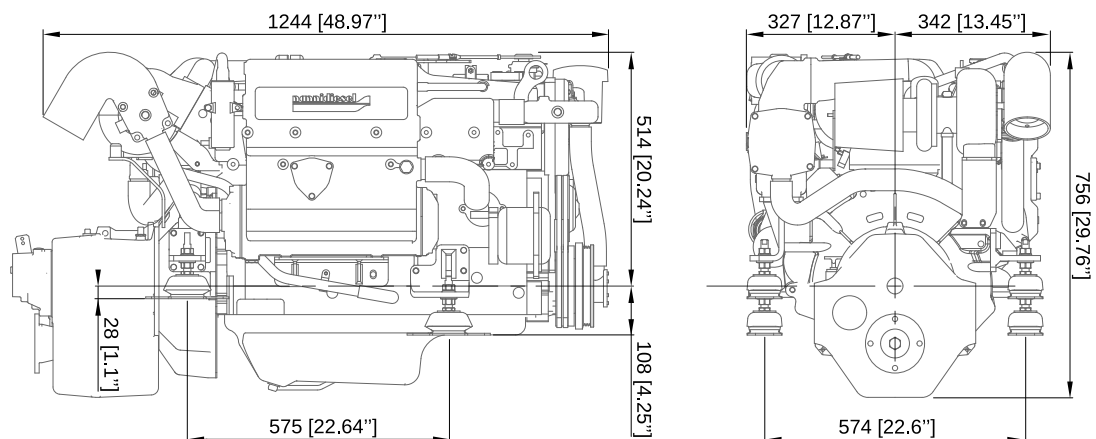

### Nanni Industries S.A.S. France

11, Avenue Mariotte - Zone Industrielle  
33260 La Teste - France  
Tel: +33 (0)5 56 22 30 60  
Fax: +33 (0)5 56 22 30 79

### Nanni Trading S.R.L

Via Degli Olmetti, 5/B  
00060 Formello (RM) - Italia  
Tel: +39 (0)6 30 88 42 51/52/53  
Fax: +39 (0)6 30 88 42 54

Technical data according to ISO 8665. Specifications are subject to change without notice. Images and illustrations may show non standard equipments. All combination of equipment & accessory are not available.

120914-ENG